

GD7020 Series

70x70x20mm (2.8"x2.8"x0.8")



Fan Frame: Thermoplastic PBT UL 94V-0
 Fan Impeller: Thermoplastic PBT UL 94V-0
 Bearing system: Ball bearing and Sleeve bearing available
 Operation Temp: -30~70°C (Ball bearing)
 -10~55°C (Sleeve bearing)
 Service Life: 70000hours @40°C (Ball bearing)
 30000hours @40°C (Sleeve bearing)
 Weight: 59.3g

Engineering Drawing (mm)

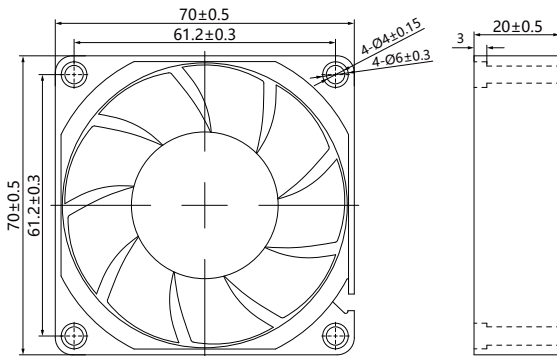

Air Performance

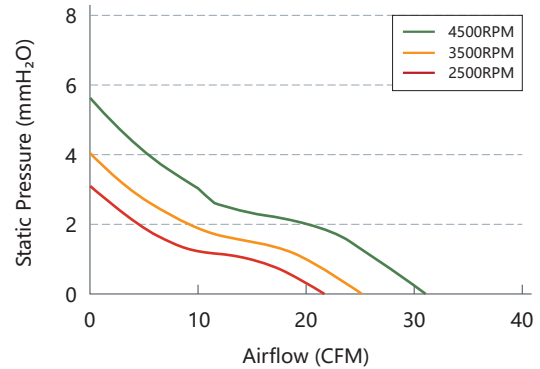

Available Functions

Motor protection

RP SS AS CL OVP

Signal output

FG RD RDB LD

Speed control mode

PWM TC VC CC CS

Specifications

Model	Voltage	Voltage Range	Current	Power	Speed	Maximum Air Flow	Maximum Air Pressure	Noise		
No.	VDC	VDC	A	W	RPM	m ³ /min	CFM	mmH ₂ O	INH ₂ O	dB(A)
GD7020L12	12	6.0 to 13.5	0.12	1.44	2500	0.489	17.29	2.068	0.082	31.2
GD7020L24	24	18 to 26.5	0.08	1.92	3500	0.723	25.54	4.135	0.163	35.2
GD7020M12	12	6.0 to 13.5	0.24	2.88	4500	1.004	35.48	7.494	0.295	39.4
GD7020M24	24	18 to 26.5	0.13	3.12						
GD7020H12	12	6.0 to 13.5	0.35	4.2						
GD7020H24	24	18 to 26.5	0.22	5.28						

DC Axial Fan - GD Series
DC Radial Fan - GRD Series
EC Axial Fan - GE Series